

REV STATUS		REV STATUS	
SYN	DESCRIPTION	DATE	APPROVED

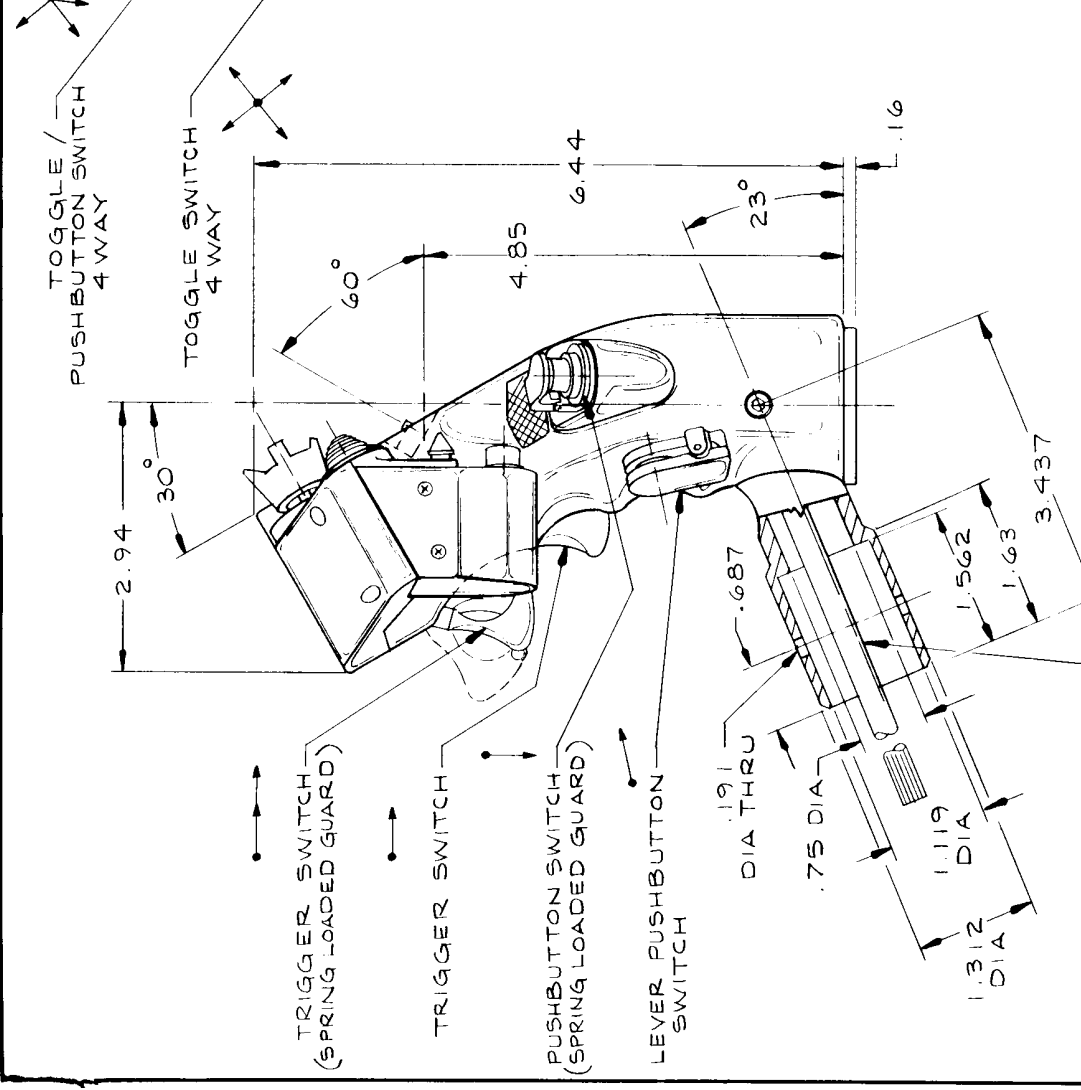

FIND NO	QTY	CODE	IDENTIFYING NUMBER	PART OR IDENTIFYING NUMBER	NOMENCLATURE OR DESCRIPTION	NOTE
MATERIALS OR PARTS LIST						
UNLESS OTHERWISE SPECIFIED DIMENSIONS ARE IN INCHES						
TOLERANCES						
DECIMALS	ANGLES	SURF FINISH				
XX ± 01	± 1°	✓				
XXX ± 005						
HEAT TREAT FINISH						
SYMBOLS						
PARTS LIST						
FIND NO						
APPROVED						
CHECKED						
PREPARED						
SIZE CODE IDENT NO						
C 81579						
SCALE / WT						
SHEET						

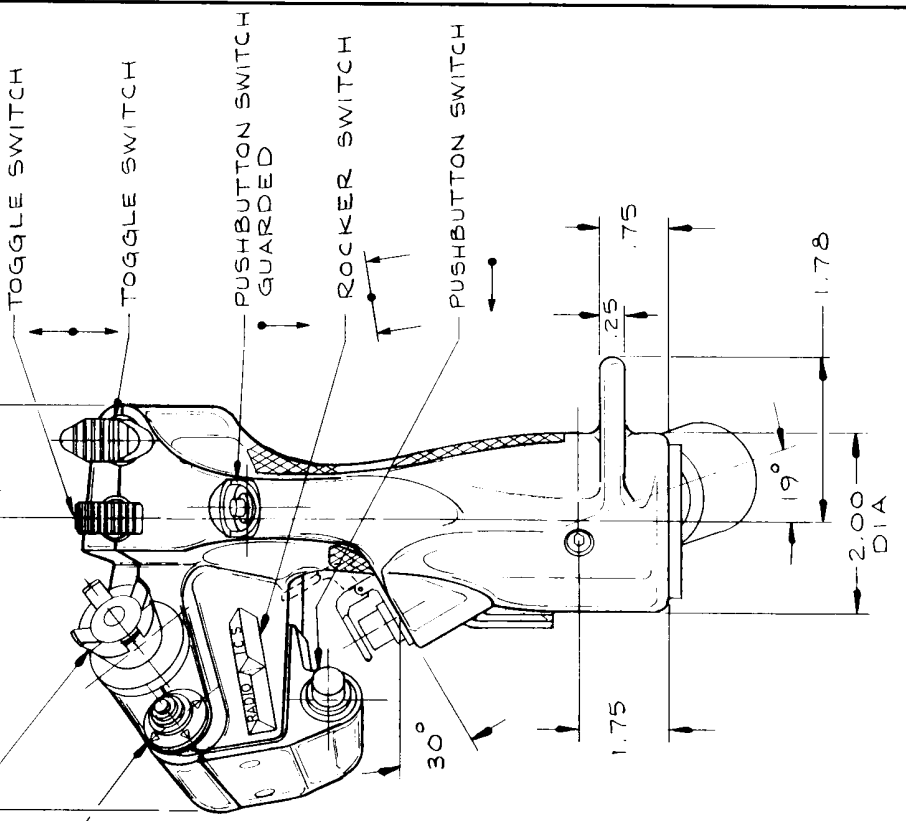

MASON ELECTRIC COMPANY, INC

GRIP ASSEMBLY CONTROL

MATERIAL: MOLED FIBER FILLED THERMOSETTING PLASTIC WITH METAL ADAPTER

2. DIMENSIONS APPLY AFTER PLATING.
1. REMOVE ALL BURRS AND SHARP EDGES; SPRUE AND ALL FLASH; GATES, FINS AND RISERS.

NOTES, GENERAL, UNLESS OTHERWISE SPECIFIED AND AS APPLICABLE: